

A-A

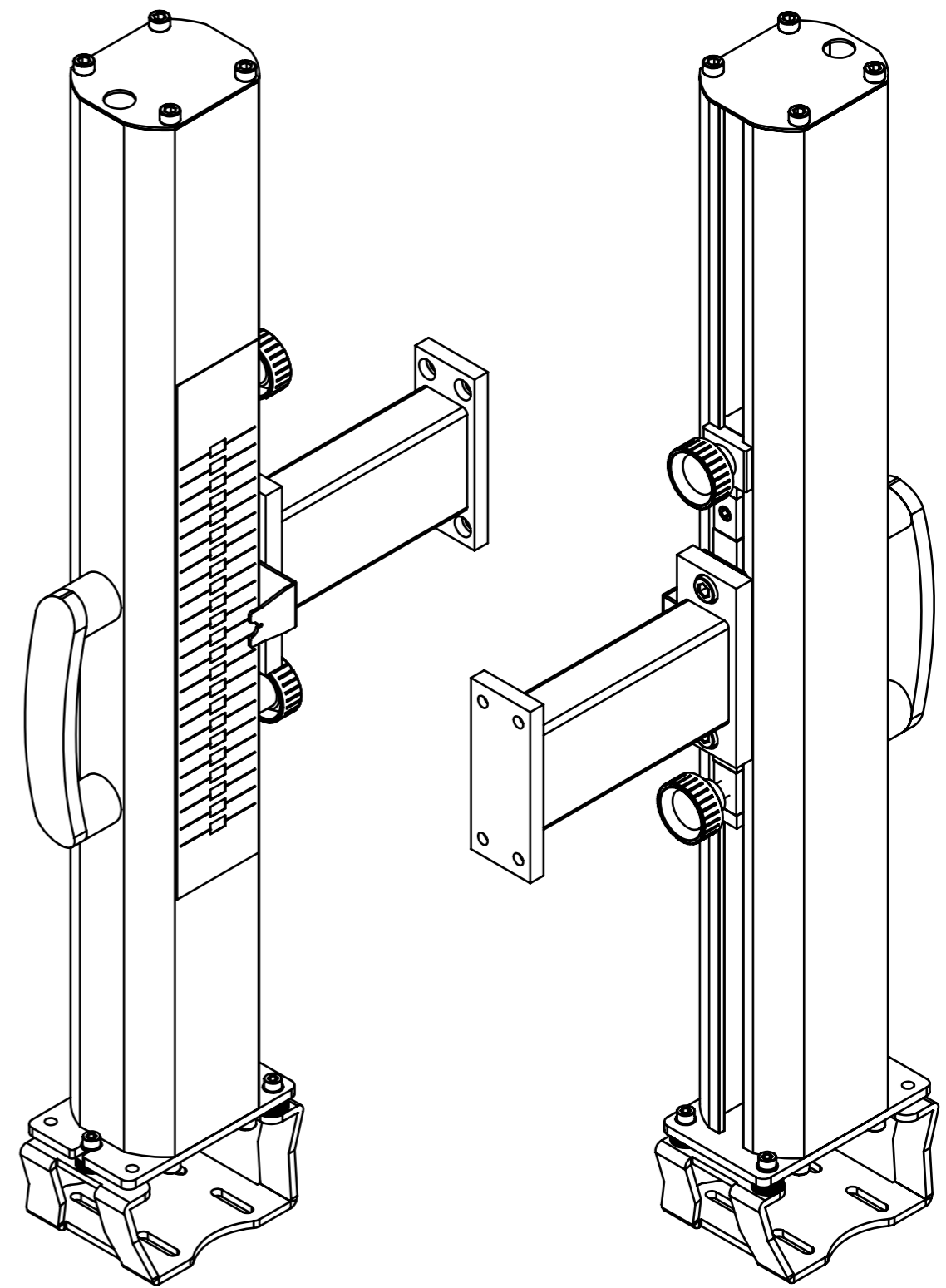

Staffatura TX manuale corsa 400

Disegno
SMART 400 TX

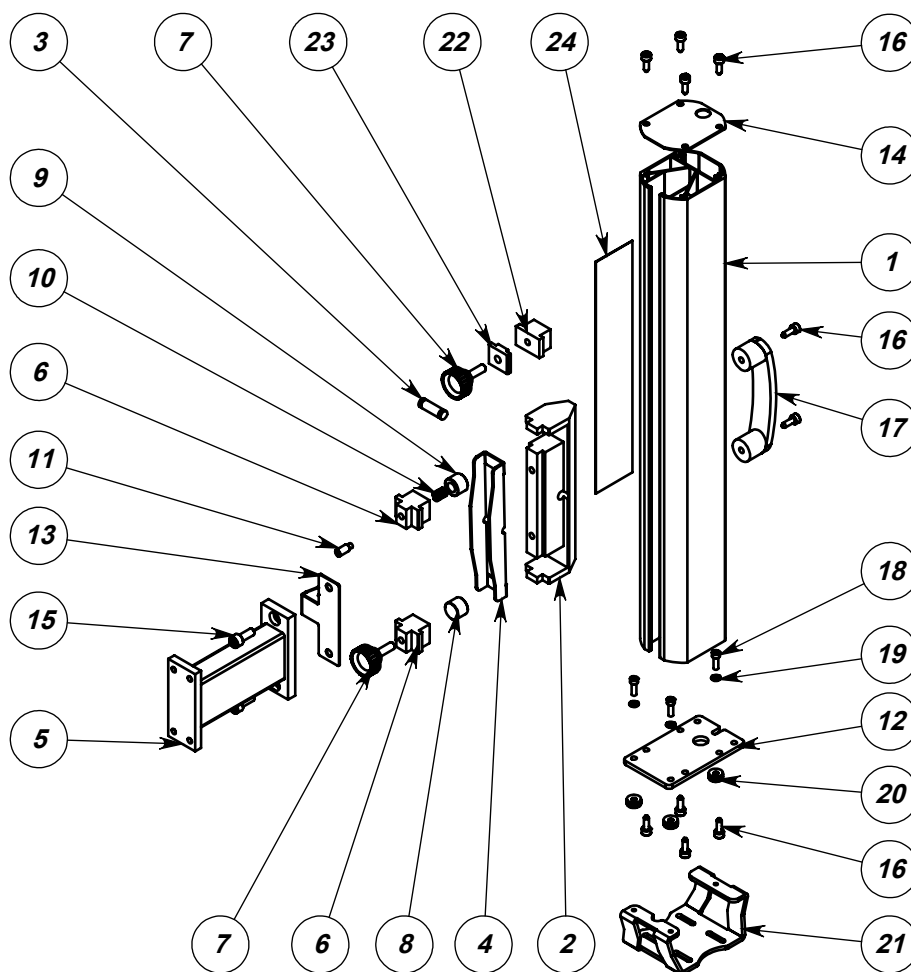

Pos	Codice	Descrizione	Default/Quantità
1	25011120	Profilo lungo 600	1
2	25011121	Cursore	1
3	25011128	Perno	1
4	25011127	Leva	1
5	25010033	Supporto L 150	1
6	25011122	Supporto pistone	2
7	90100218	Manopola BT.32 p-M8x25 6755	2
8	25011129	Pistone	1
9	25011123	Pistone molla	1
10	90150106	Molla D int. 6 - filo D 2 - passo 3.5 - lunga 13mm	1
11	90080805	VSTEI UNI 5925 M8X20 punta cilindrica	1
12	25011125	Piastra inferiore	1
13	25011126	Segnalatore	1
14	25011124	Piastra superiore	1
15	90020801	Vite TCEI M8x20	2
16	90090202	Vite TCEI aut. 5.5x16	10
17	90100307	Maniglia EBP.140-6-C1 (260210-C1)	1
18	90020502	Vite TCEI M 5 x 16 UNI 5931 zincata	3
19	90070203	Rondella piana 5x10	3
20	90150103	Molla tazza	18
21	25032128	Supporto DSP	1
22	25011159	Blocco	1
23	25011160	Piastrina blocco	1
24	25011161	Adesivo 220 mm	1