

Back register for **torsion bar presses and RG Amada / Promecam.**
Suitable for machines up to 60 Ton.

BRUSHLESS COD. 022CH100

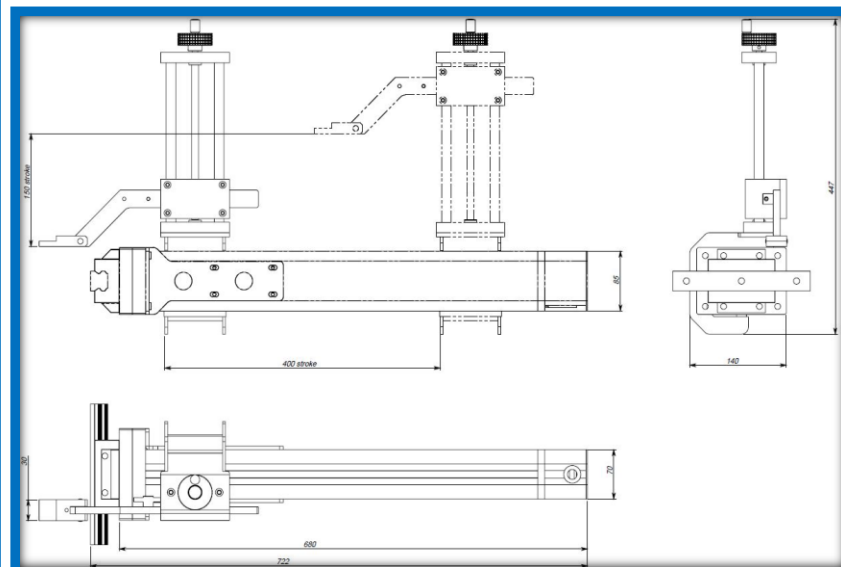
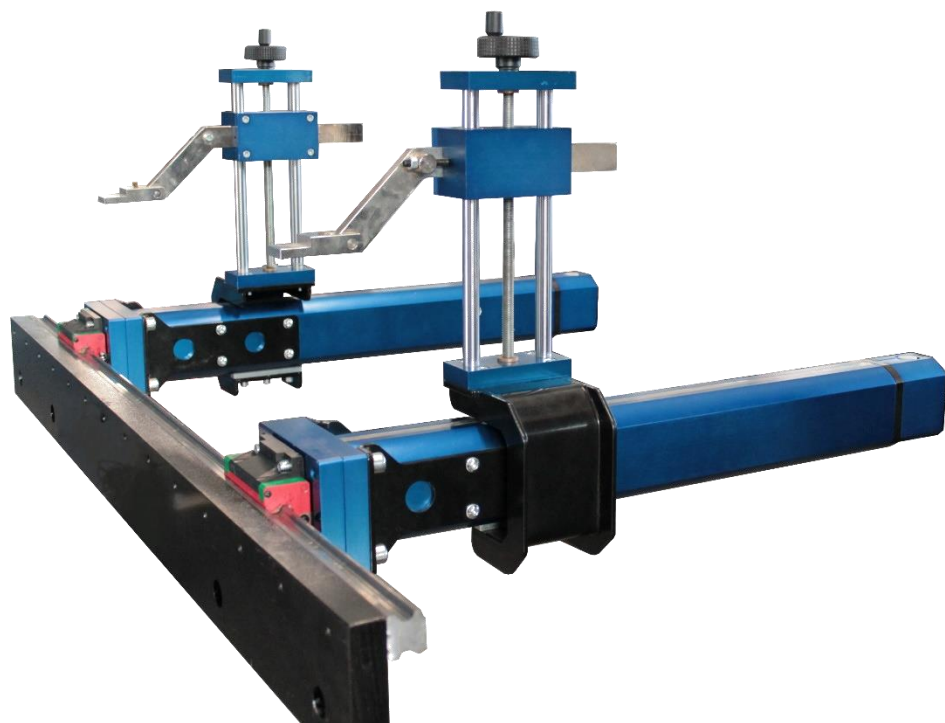

TRIVENETA IMPIANTI S.r.l.

Administrative Headquarters: Via Scopella, 22 - 37060 Castel d'Azzano VR – Italy

Operational Headquarters: Via Bovolino, 18/B - 37060 Buttapietra VR - Italy

Phone: +39 045 518 747 - Fax +39 045 854 56 05 - Web Site: www.trivenetaimpianti.com E-mail: sales@trivenetaimpianti.com

MOVEMENT AXIS

Axis X1 and X2 independent

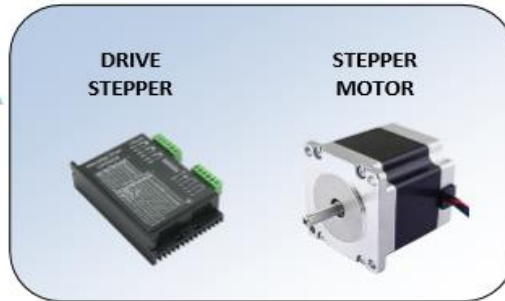
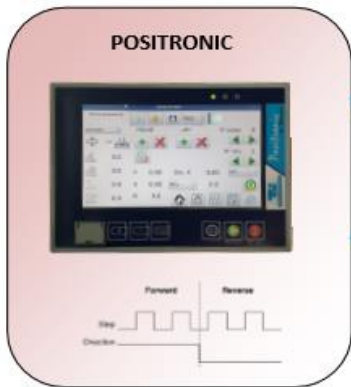

AXIS R1 and R2



Manual

AXIS Y



Stepper