



TRIVENETA SISTEMI

Kit Smart X2

COD. 029 M2

Registro posteriore per presse a barra di torsione e RG Amada/Promecam.
Indicato per macchine fino a 60 Ton.

BRUSHLESS COD. 022CH100

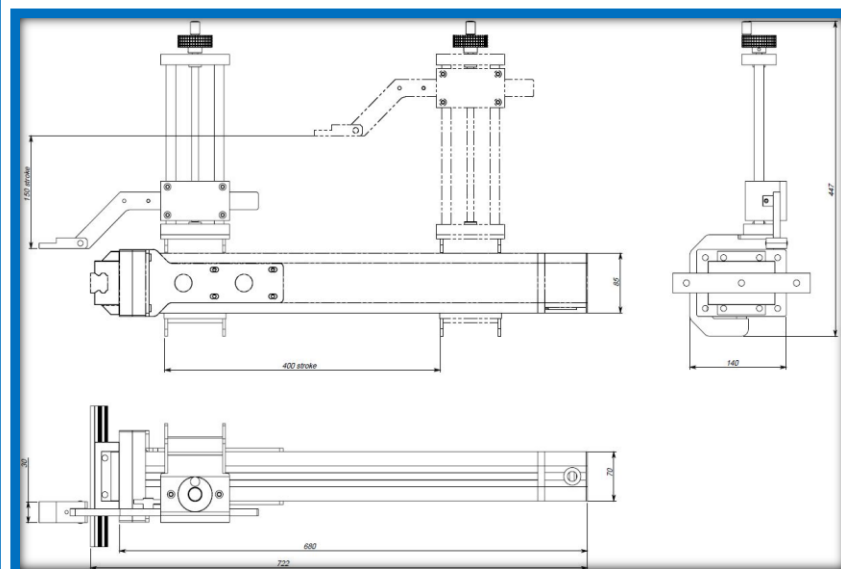
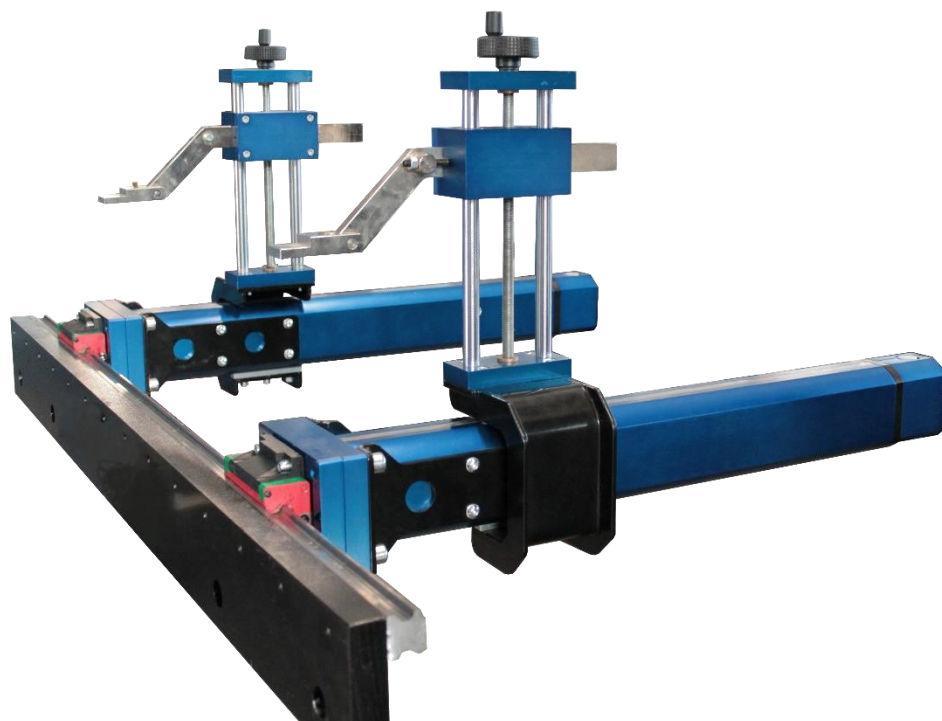

TRIVENETA IMPIANTI S.r.l.

Sede Amministrativa: Via Scopella, 22 - 37060 Castel d'Azzano VR - Italia

Sede Operativa: Via Bovolino, 18/B - 37060 Buttapietra VR - Italia

Telefono: +39 045 518 747 - Fax +39 045 854 56 05 - Sito web: www.trivenetaimpianti.com E-mail: sales@trivenetaimpianti.com

ASSI DI MOVIMENTO

Asse X1 e X2 indipendenti

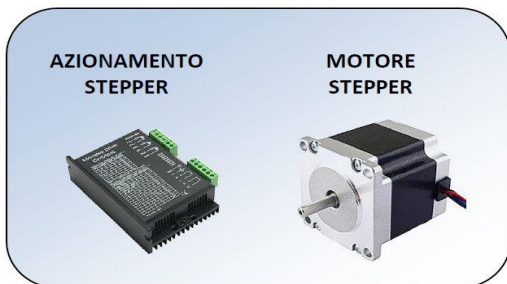
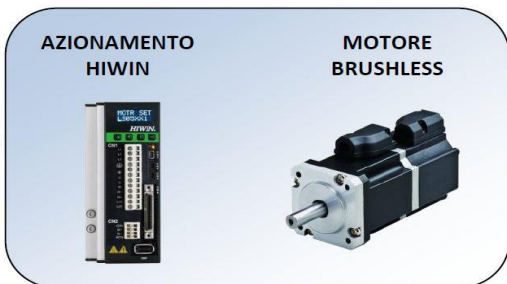

ASSI R1 e R2



Manuali

ASSE Y

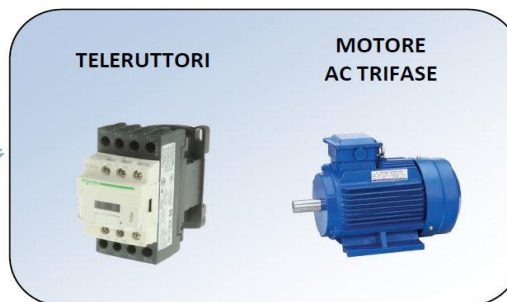

Stepper